



INSTALLATION INSTRUCTIONS FOR SUTERA SS-4

SEMI IN-GROUND STEEL LID 4 cu.yd. CONTAINMENT CAPACITY





SUTERA™
INSTALLATION
INSTRUCTIONS
SS-4

* TOP OF PRECAST
 CONCRETE TO BE 36.0"
 ABOVE FIN. GRADE.
 PROVIDE A MIN. 3%
 GRADE SLOPING
 AWAY FROM UNIT.

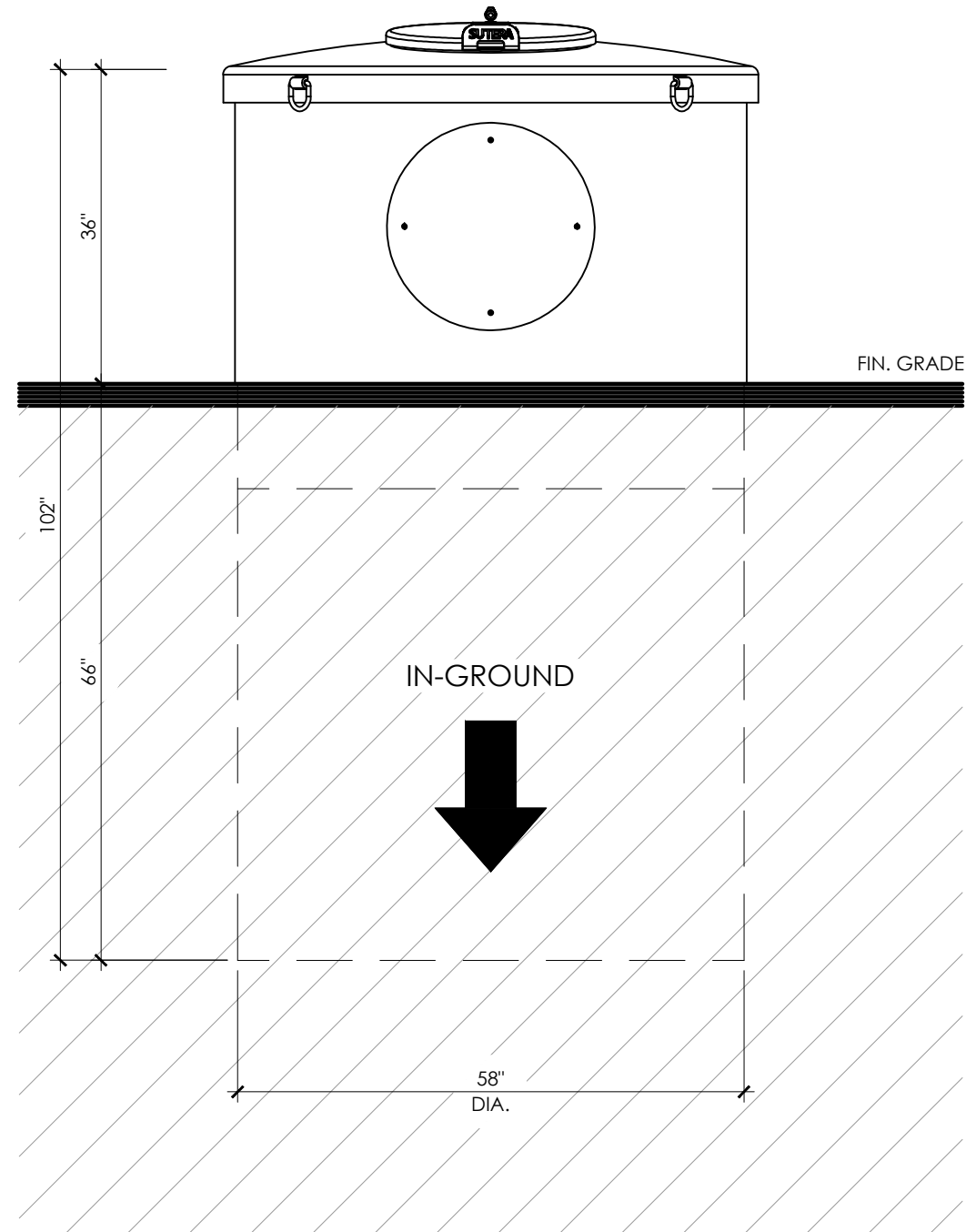

INSTALLATION INSTRUCTIONS

REQUIRED TOOLS, EQUIPMENT, MACHINERY:

- EXCAVATOR
- DUMP TRUCK
- JUMPING JACK, PLATE COMPACTOR
- BUILDERS LEVEL
- STORY ROD
- HAND LEVEL (6ft.)
- LASER LEVEL
- TAPE MEASURE
- HAND SHOVEL
- HAND RAKE
- LIFTING STRAPS FOR PRECAST CONCRETE AND STEEL LID

STEP No.1 - DETERMINE SITE LOCATION (SEE PG.2)

- a. NO OVERHEAD POWER LINES
- b. NO TREE OVERHANG
- c. NO CANOPY OVERHANG
- d. HAVE A SITE UTILITY LOCATE (UNDERGROUND) CONDUCTED WITHIN AREA OF PROPOSED INSTALLATION
- e. BE WITHIN REACH OF SERVICE CRANE TRUCK

STEP No.2 - EXCAVATION (SEE PG.3)

- a. TOP OF PRECAST TO BE 36.0" ABOVE FINISHED GRADE. PROVIDE A MIN. 3% GRADE SLOPING AWAY FROM UNIT.
- b. EXCAVATE TO THE REQUIRE WIDTH AND DEPTH.
- c. LEVEL AND COMPACT THE BASE OF EXCAVATION.
- d. APPROX. 3.7 cu.yds. OF MATERIAL TO BE REMOVED FROM SITE PER SUTERA SS-4.

STEP No.3 - INSTALLATION OF PRECAST CONCRETE (SEE PG.4)

- a. TAKE DELIVERY OF PRECAST UNITS WITH DELIVERY TRUCK CRANE, SITE CRANE OR EXCAVATOR, WHICHEVER IS AVAILABLE OR REQUIRED.
- b. USING SWIFT LIFT HOOK ANCHORS, 2 PER PRECAST UNIT, LIFT THE PRECAST MONOBASE AND SET INTO PLACE, ENSURE LEVEL, BOTH HORIZ. AND VERT.
- c. INSTALL THE CONTINUOUS WATER TIGHT GASKET.
- d. USING SWIFT LIFT HOOK ANCHORS, 2 PER PRECAST UNIT, LIFT THE PRECAST RISER AND SET INTO PLACE, ENSURE LEVEL, BOTH HORIZ. AND VERT.
- e. ENSURE TOP OF PRECAST IS 6.0" ABOVE FINISHED GRADE, PROVIDE A MIN. 3% GRADE SLOPING AWAY FROM UNIT.
- f. DO NOT ALLOW DEBRIS OR WATER TO ENTER THE OPEN CONCRETE WELL, KEEP CLEAN AND DRY.

STEP No.4 - BACKFILL (SEE PG.5)

- a. SUTERA UNITS OVERALL MASS EXCEED THE NATURAL FORCES OF HYDROSTATIC PRESSURE AND WILL NOT FLOAT OUT OF THE GROUND, NO EXTRA MEASURES ARE REQUIRED TO KEEP IT IN THE GROUND.
- b. BACKFILL WITH NATIVE MATERIAL (EXCAVATED MATERIAL MAY BE USED IF SUITABLE).
- c. COMPACT IN SMALL LAYERS TO ACHIEVE 95% PROCTOR.
- f. DO NOT ALLOW DEBRIS OR WATER TO ENTER THE OPEN CONCRETE WELL, KEEP CLEAN AND DRY.

STEP No.5 - FASTENING REUSABLE PVC BAG TO STEEL LID (SEE PG.6)

- a. LIFT THE STEEL LID WITH THE REQUIRED LIFTING STRAPS CONNECTED TO THE THREE (3) WELDED D-RINGS AND SUSPEND IN AIR TO ALLOW FASTENING OF PVC BAG (STEEL LID AND BAG WEIGHT 405 lbs (184 kg) WHEN EMPTY).
- *CAUTION* - DO NOT STAND DIRECTLY UNDERNEATH THE STEEL LID
- b. LOOP THE SIX (6) NYLON STRAPS ATTACHED TO THE REUSABLE PVC BAG AROUND THE SIX (6) FOOTMAN LOOPS ATTACHED TO THE UNDERSIDE OF THE STEEL LID.
- c. FASTEN THE NYLON LOOPS WITH QUICK LINKS, SIX (6) IN TOTAL, ENSURE THE QUICK LINK NUTS ARE TIGHTEN.

STEP No.6 - BAG HARDWARE AND CINCHING BAG CLOSED (SEE PG.7)

- a. PULL ROPE TIGHTLY THROUGH THE HEAVY DUTY HOSE ASSEMBLY.
- b. INSERT ROPE HOSE ASSEMBLY BALL INTO BALL SLOT OF CLAMCLEAT.
- c. ENSURE ROPE IS ENGAGED INTO THE TEETH OF THE CLAMCLEAT.
- d. FASTEN ROPE BEHIND THE CLAMCLEAT HOOK.
- *THE ABOVE STEPS WILL CINCH THE BOTTOM OF THE BAG CLOSED.
- e. PULLING THE ROPE TIGHT, TIE A DOUBLE HALF HITCH KNOT TO THE SECONDARY SAFETY ROPE TIE-OFF.
- f. NEATLY PLACE THE REMAINING ROPE INTO THE ROPE POUCH.

STEP No.7 - PLACING STEEL LID AND BAG INTO THE PRECAST WELL (SEE PG.8)

- a. LOWER THE STEEL LID WITH THE REUSABLE PVC BAG ATTACHED INTO THE PRECAST CONCRETE WELL.
- b. TAKE CAUTION NOT TO PINCH OR TEAR THE BAG WHEN LOWERING INTO THE WELL.
- c. TURN THE STEEL LID WHILE LOWERING TO HAVE THE ACCESS LID FACING THE DESIRED DIRECTION.

STEP No.8 - IDENTIFICATION SIGNAGE (SEE PG.9)

- a. 24" inch DIA. 3M LABEL MOUNTED ON PRE-ROLLED ALUMINUM PLATE.
- b. FOUR (x4) REMOVABLE ZINC ALLOY ANCHORS HOLD SIGN IN PLACE.
- c. USING THE PRE-DRILLED HOLES ON THE SIGNAGE, MARK AND DRILL FOUR (x4) 0.25" DIA. HOLES IN PRECAST, 1.75" DEEP. HAMMER GENTLY ANCHORS INTO PLACE, TAKING CAUTION NOT TO DAMAGE THE SIGNAGE.

INSTALLATION IS NOW COMPLETE

NOTE:
 ALL DIMENSIONS ARE
 IN INCHES UNLESS
 OTHERWISE SPECIFIED

DETERMINE SITE LOCATION

STEP No.1



INSTALLATION INSTRUCTIONS

SS-4

- STEP No.1 - DETERMINE SITE LOCATION
- a. NO OVERHEAD POWER LINES
 - b. NO TREE OVERHANG
 - c. NO CANOPY OVERHANG
 - d. HAVE A SITE UTILITY LOCATE (UNDERGROUND) CONDUCTED WITHIN AREA OF PROPOSED INSTALLATION
 - e. BE WITHIN REACH OF SERVICE CRANE TRUCK

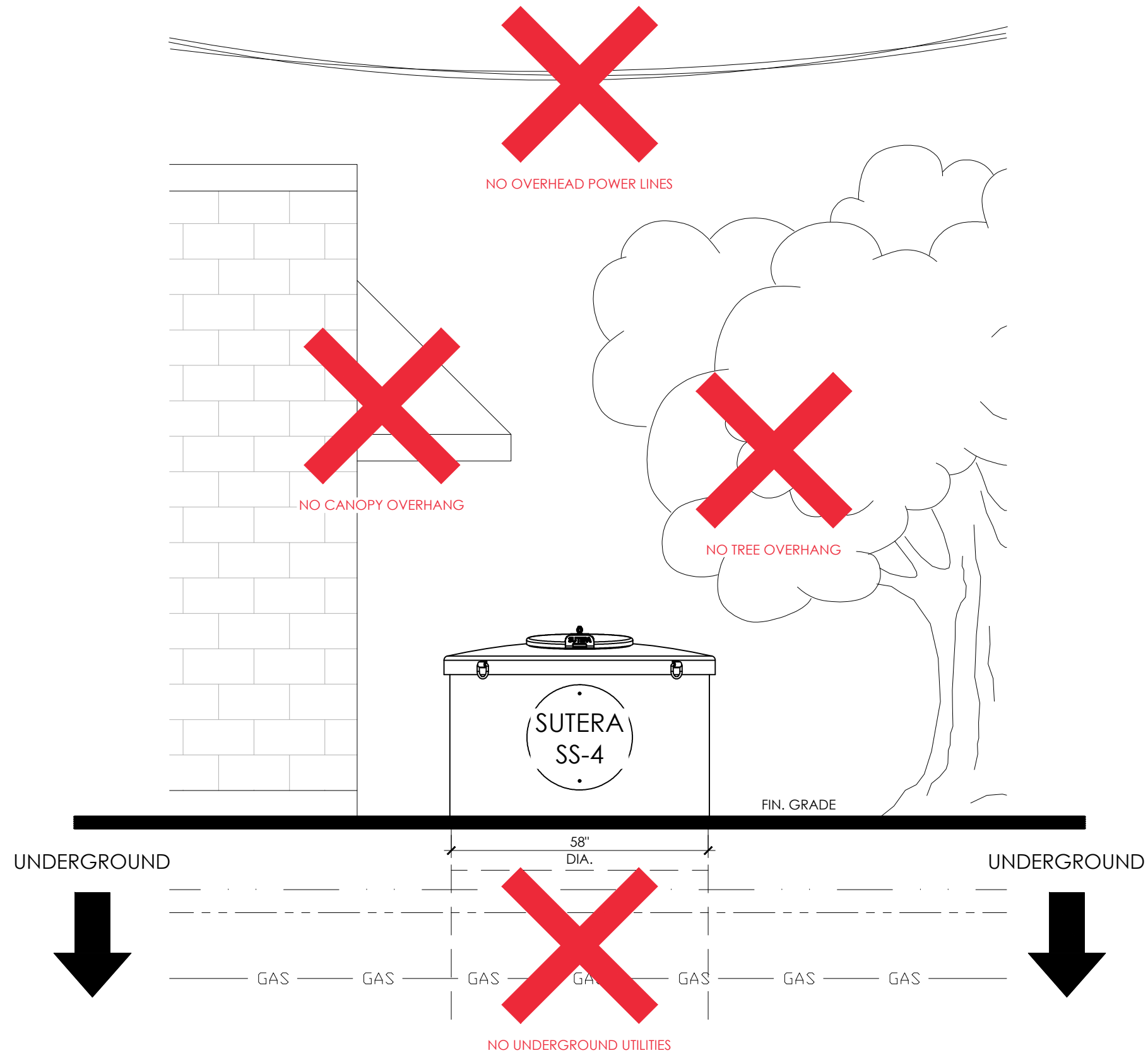

NOTE:
ALL DIMENSIONS ARE
IN INCHES UNLESS
OTHERWISE SPECIFIED

EXCAVATION

STEP No.2



INSTALLATION
INSTRUCTIONS

SS-4

STEP No.2 - EXCAVATION

- TOP OF PRECAST TO BE 6.0" ABOVE FINISHED GRADE. PROVIDE A MIN. 3% GRADE SLOPING AWAY FROM UNIT.
- EXCAVATE TO THE REQUIRE WIDTH AND DEPTH.
- LEVEL AND COMPACT THE BASE OF EXCAVATION.
- APPROX. 3.7 cu.yds. OF MATERIAL TO BE REMOVED FROM SITE PER SUTERA SS-4.

NOTE:
ALL DIMENSIONS ARE
IN INCHES UNLESS
OTHERWISE SPECIFIED

pg. 3 of 9

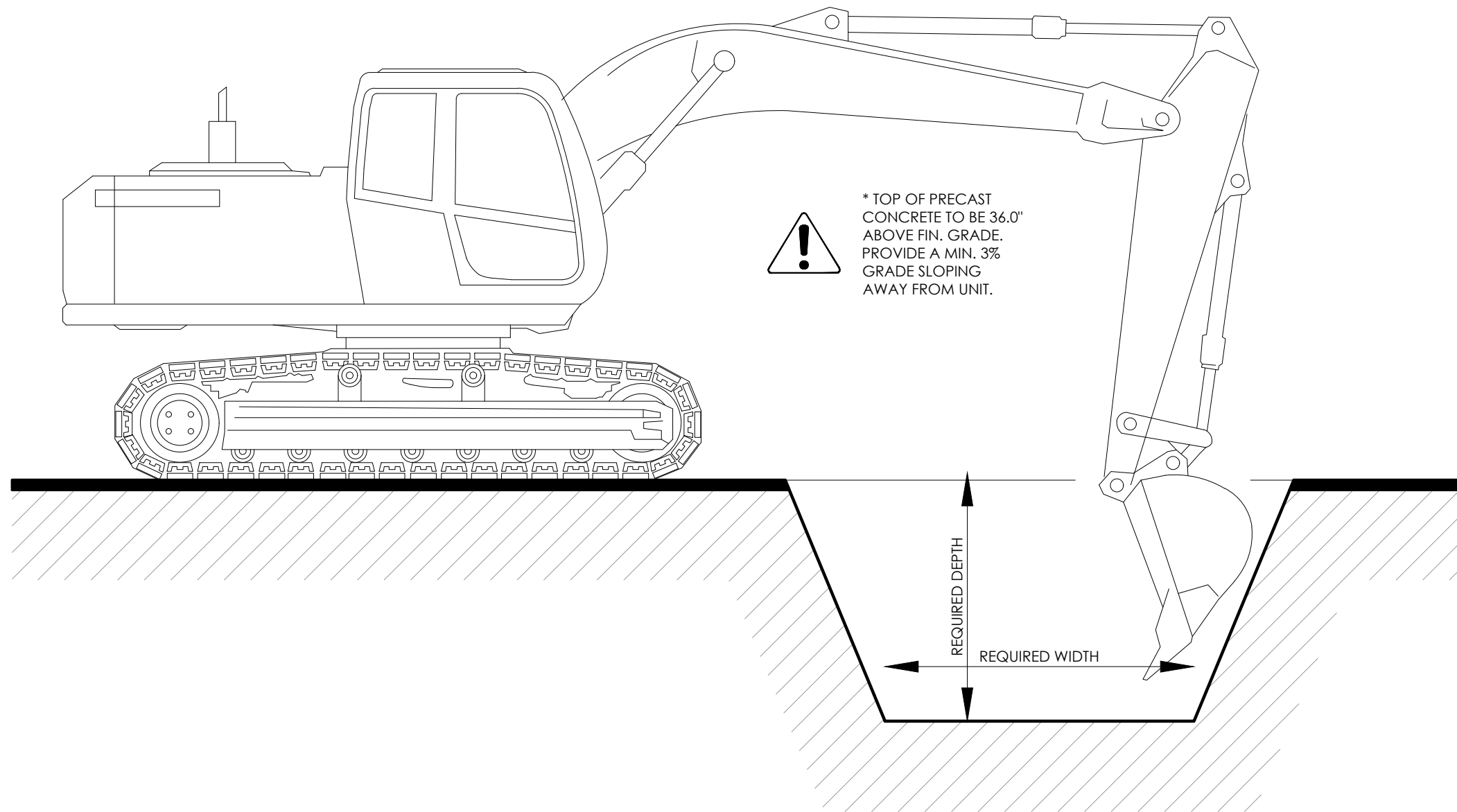

INSTALLATION OF PRECAST CONCRETE

STEP No.3



INSTALLATION INSTRUCTIONS

SS-4

HANDLING PRECAST WITH SWIFT LIFT HOOK ANCHORS

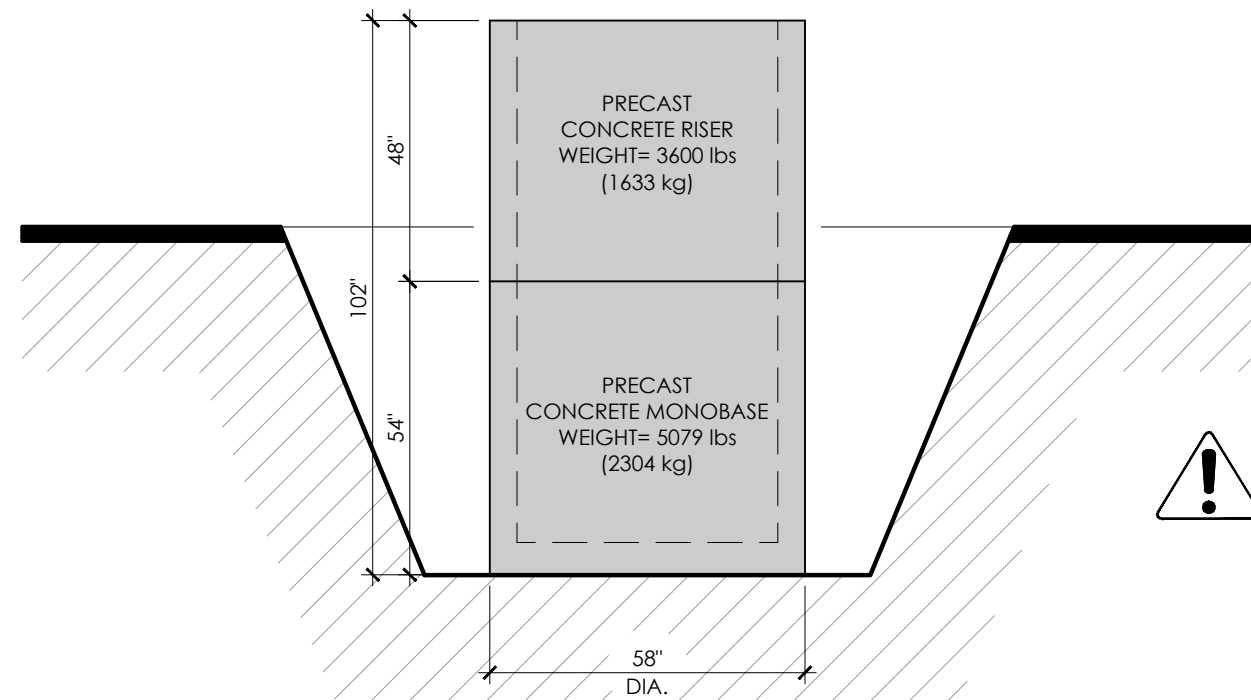
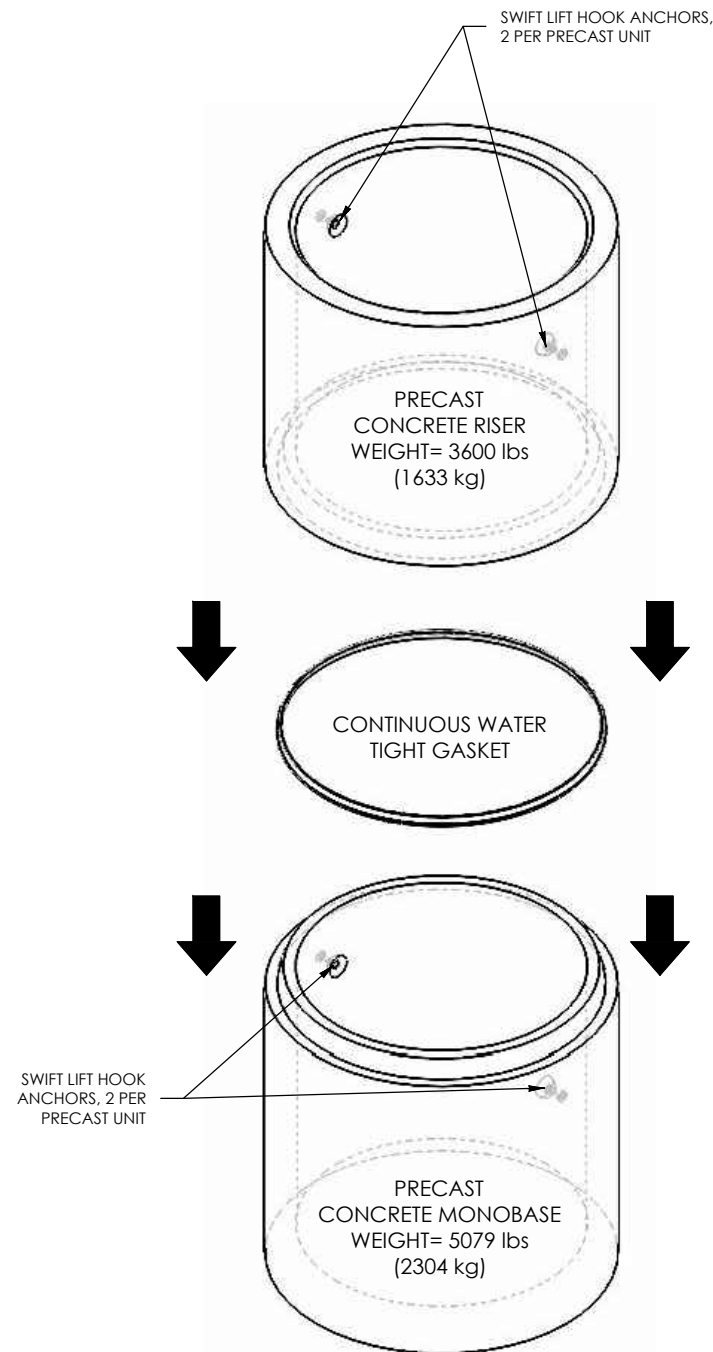
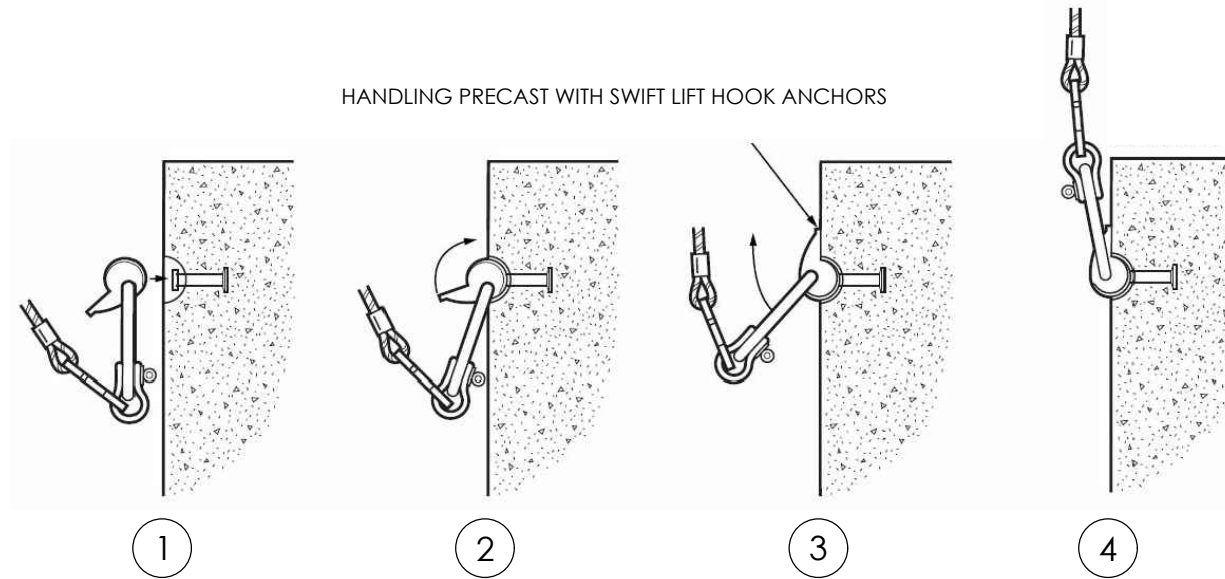

* ENSURE CONTINUOUS WATER TIGHT GASKET IS INSTALLED PRIOR TO SETTING PRECAST CONCRETE RISER IN PLACE.



- STEP No.3 - INSTALLATION OF PRECAST CONCRETE
- TAKE DELIVERY OF PRECAST UNITS WITH DELIVERY TRUCK CRANE, SITE CRANE OR EXCAVATOR, WHICHEVER IS AVAILABLE OR REQUIRED.
 - USING SWIFT LIFT HOOK ANCHORS, 2 PER PRECAST UNIT, LIFT THE PRECAST MONOBASE AND SET INTO PLACE, ENSURE LEVEL, BOTH HORIZ. AND VERT.
 - INSTALL THE CONTINUOUS WATER TIGHT GASKET.
 - USING SWIFT LIFT HOOK ANCHORS, 2 PER PRECAST UNIT, LIFT THE PRECAST RISER AND SET INTO PLACE, ENSURE LEVEL, BOTH HORIZ. AND VERT.
 - ENSURE TOP OF PRECAST IS 6.0" ABOVE FINISHED GRADE, PROVIDE A MIN. 3% GRADE SLOPING AWAY FROM UNIT.
 - DO NOT ALLOW DEBRIS OR WATER TO ENTER THE OPEN CONCRETE WELL, KEEP CLEAN AND DRY.

NOTE:
ALL DIMENSIONS ARE IN INCHES UNLESS OTHERWISE SPECIFIED

BACKFILL

STEP No.4



INSTALLATION
INSTRUCTIONS

SS-4

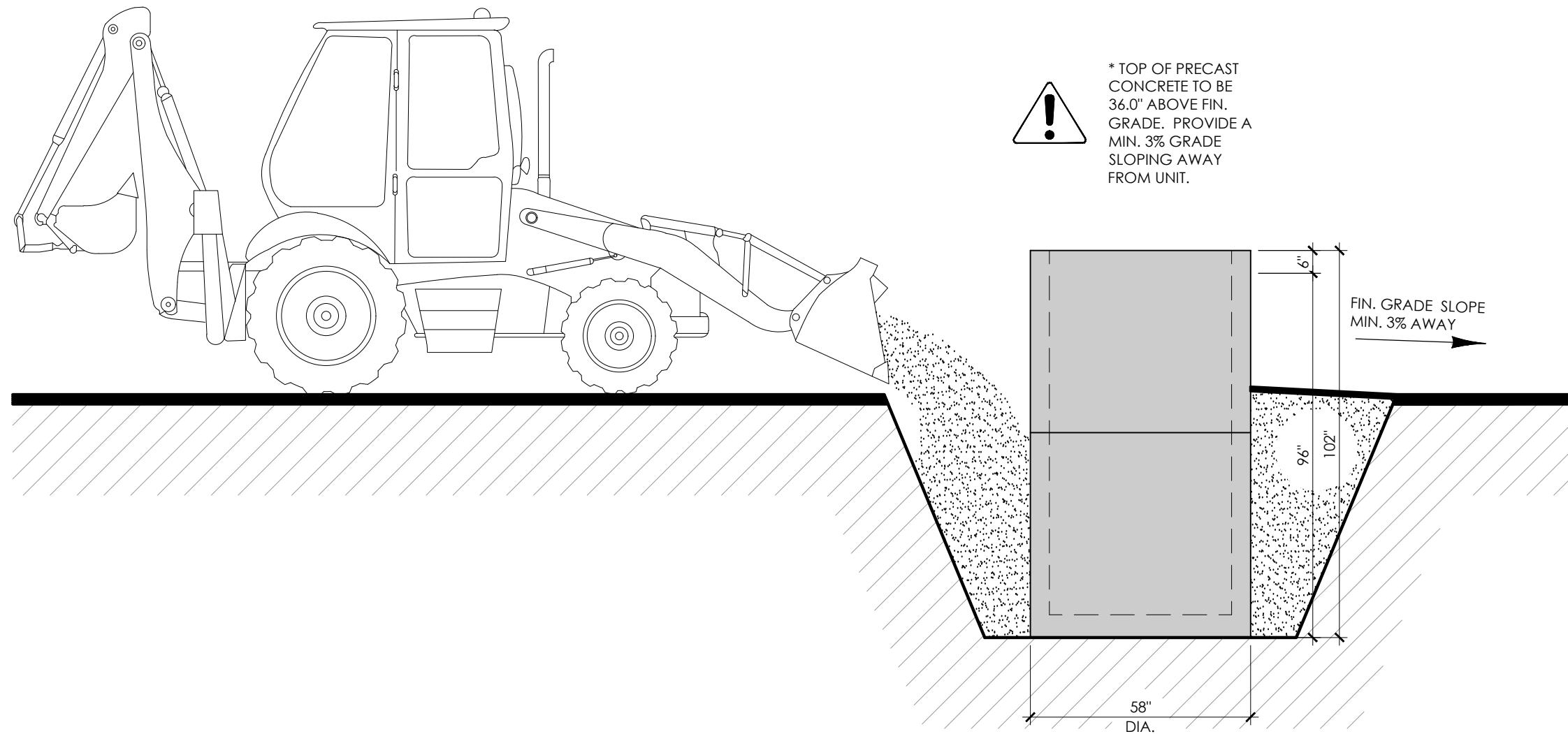

STEP No.4 - BACKFILL

- SUTERA UNITS OVERALL MASS EXCEED THE NATURAL FORCES OF HYDROSTATIC PRESSURE AND WILL NOT FLOAT OUT OF THE GROUND, NO EXTRA MEASURES ARE REQUIRED TO KEEP IT IN THE GROUND.
- BACKFILL WITH NATIVE MATERIAL (EXCAVATED MATERIAL MAY BE USED IF SUITABLE).
- COMPACT IN SMALL LAYERS TO ACHIEVE 95% PROCTOR.
- DO NOT ALLOW DEBRIS OR WATER TO ENTER THE OPEN CONCRETE WELL, KEEP CLEAN AND DRY.

NOTE:
ALL DIMENSIONS ARE
IN INCHES UNLESS
OTHERWISE SPECIFIED

FASTENING REUSABLE PVC BAG TO STEEL LID

STEP No.5



INSTALLATION INSTRUCTIONS

SS-4

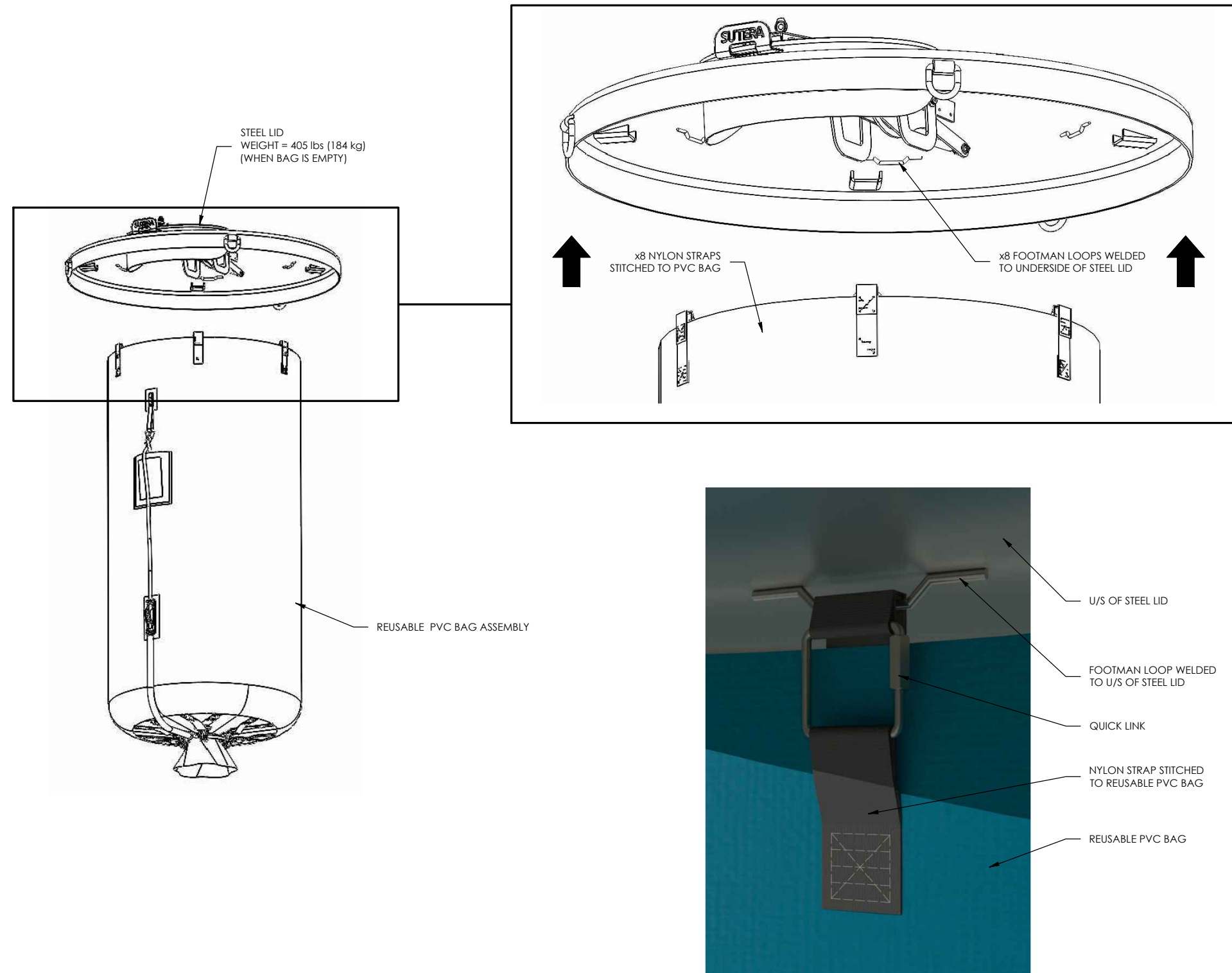

- STEP No.5 - FASTENING REUSABLE PVC BAG TO STEEL LID
- LIFT THE STEEL LID WITH THE REQUIRED LIFTING STRAPS CONNECTED TO THE THREE (3) WELDED D-RINGS AND SUSPEND IN AIR TO ALLOW FASTENING OF PVC BAG (STEEL LID AND BAG WEIGHT 405 lbs (184 kg) WHEN EMPTY).
CAUTION - DO NOT STAND DIRECTLY UNDERNEATH THE STEEL LID
 - LOOP THE SIX (6) NYLON STRAPS ATTACHED TO THE REUSABLE PVC BAG AROUND THE SIX (6) FOOTMAN LOOPS ATTACHED TO THE UNDERSIDE OF THE STEEL LID.
 - FASTEN THE NYLON LOOPS WITH QUICK LINKS, SIX (6) IN TOTAL, ENSURE THE QUICK LINK NUTS ARE TIGHTEN.

NOTE:
ALL DIMENSIONS ARE IN INCHES UNLESS OTHERWISE SPECIFIED

BAG HARDWARE AND CINCHING BAG CLOSED

STEP No.6



INSTALLATION INSTRUCTIONS

SS-4

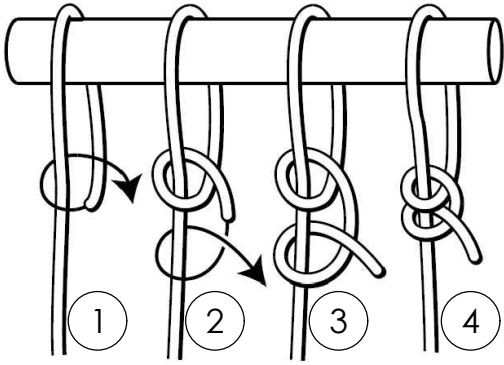
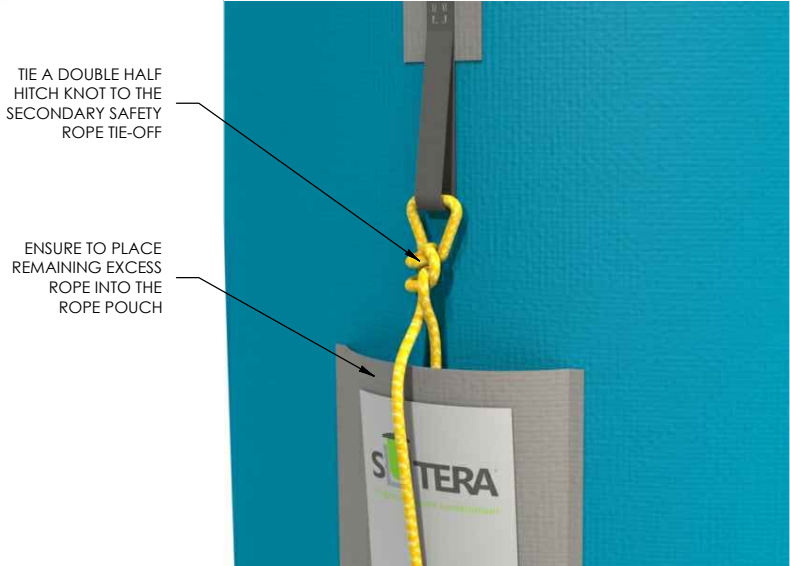
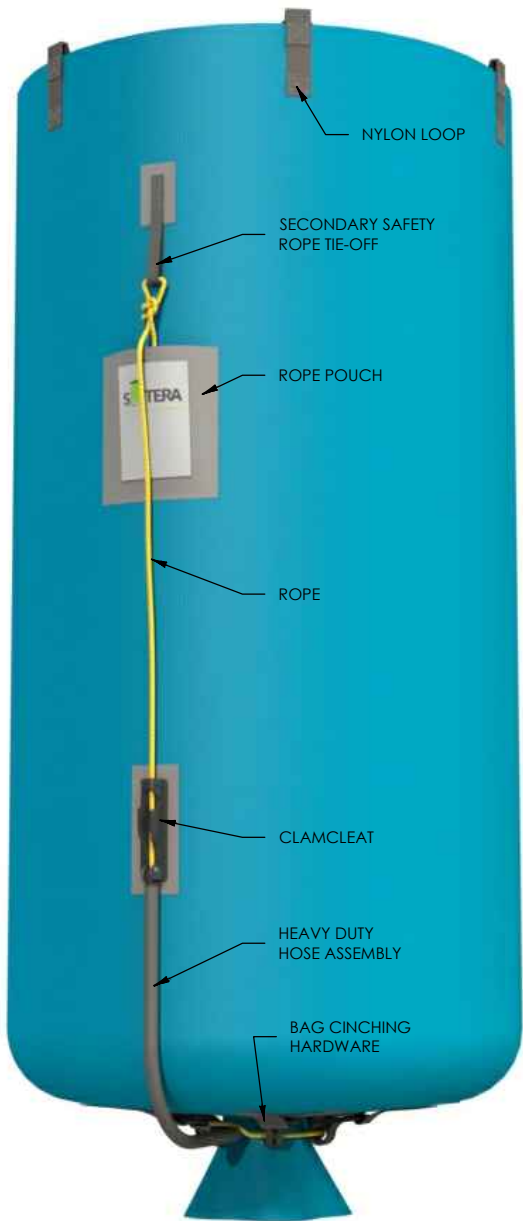

DOUBLE HALF HITCH KNOT INSTRUCTIONS

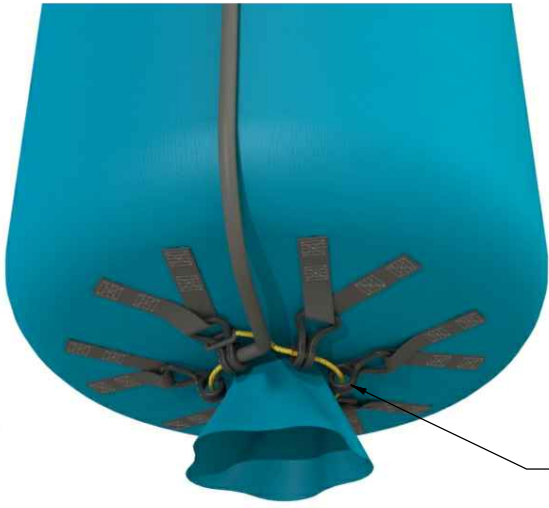
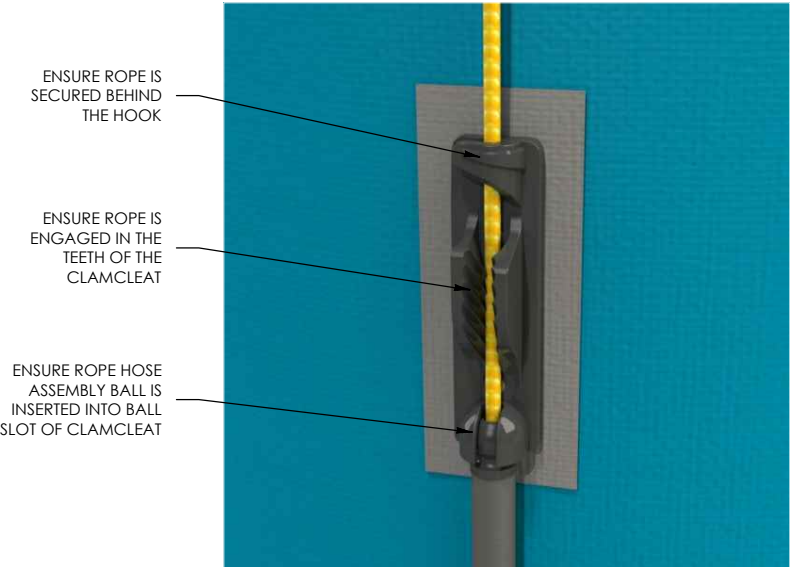

WHEN THE ROPE IS PULLED TIGHT AND SECURED IN THE CLAMCLEAT, THE BOTTOM OF THE BAG IS CINCHED CLOSED

- STEP No.6 - BAG HARDWARE AND CINCHING BAG CLOSED
- PULL ROPE TIGHTLY THROUGH THE HEAVY DUTY HOSE ASSEMBLY.
 - INSERT ROPE HOSE ASSEMBLY BALL INTO BALL SLOT OF CLAMCLEAT.
 - ENSURE ROPE IS ENGAGED INTO THE TEETH OF THE CLAMCLEAT.
 - FASTEN ROPE BEHIND THE CLAMCLEAT HOOK.
- *THE ABOVE STEPS WILL CINCH THE BOTTOM OF THE BAG CLOSED.
- PULLING THE ROPE TIGHT, TIE A DOUBLE HALF HITCH KNOT TO THE SECONDARY SAFETY ROPE TIE-OFF.
 - NEATLY PLACE THE REMAINING ROPE INTO THE ROPE POUCH.

NOTE:
ALL DIMENSIONS ARE IN INCHES UNLESS OTHERWISE SPECIFIED

PLACING STEEL LID AND BAG INTO THE PRECAST WELL

STEP No.7



INSTALLATION INSTRUCTIONS

SS-4



LOWER THE STEEL LID WITH REUSABLE PVC BAG ATTACHED, ENSURING THE BOTTOM OF THE BAG IS CINCHED CLOSED, INTO THE PRECAST CONCRETE WELL IN THE GROUND. TAKE CAUTION NOT TO PINCH OR TEAR THE BAG WHILE LOWERING IT INTO THE WELL.

STEEL LID WEIGHT:
405 lbs (184 kg)
(WHEN BAG IS EMPTY)

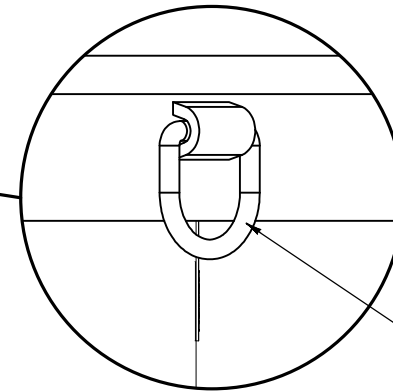

THE STEEL LID IS DESIGNED TO BE LIFTED BY THREE (3) WELDED D-RINGS

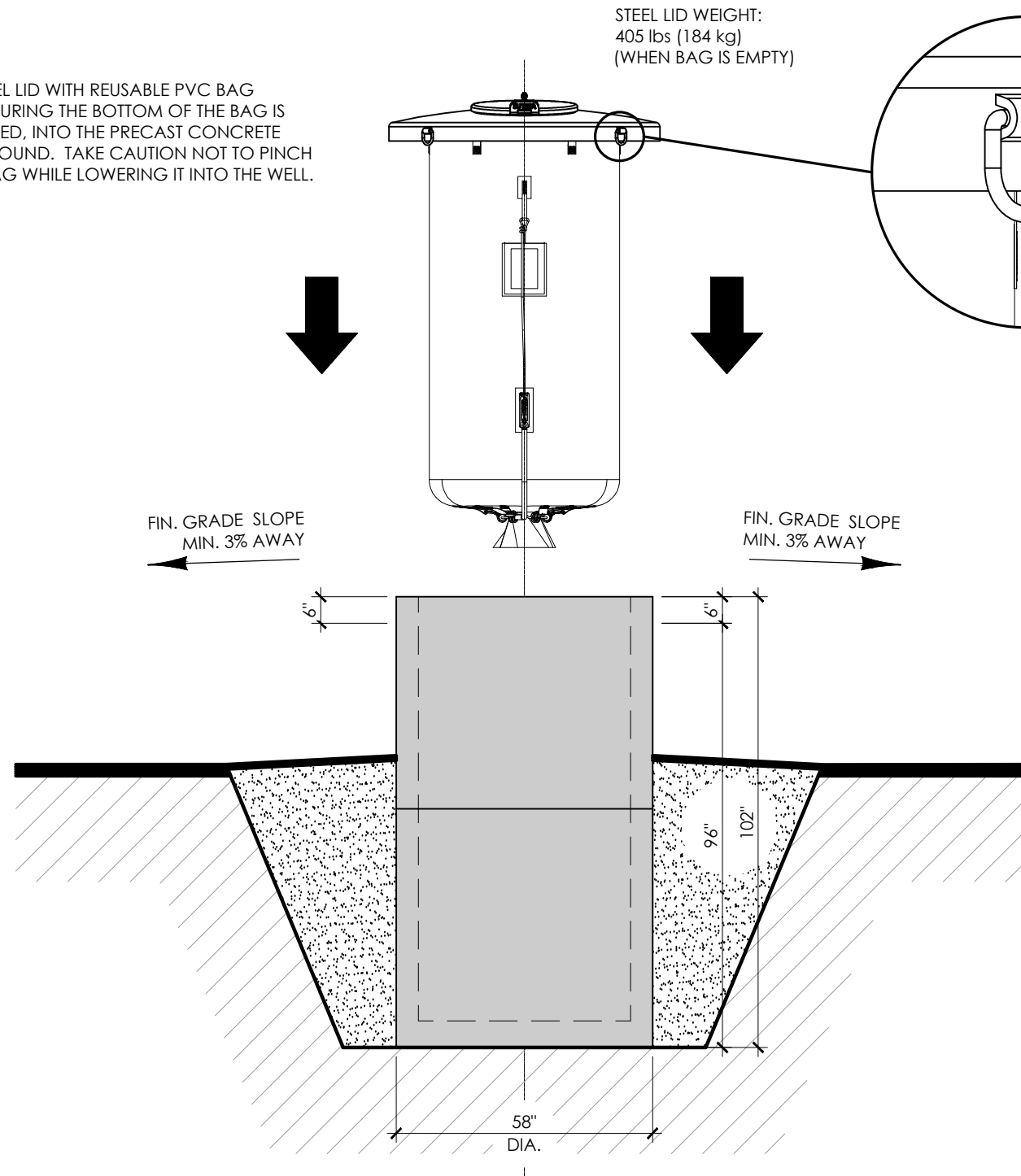

- STEP No.7 - PLACING STEEL LID AND BAG INTO THE PRECAST WELL
- LOWER THE STEEL LID WITH THE REUSABLE PVC BAG ATTACHED INTO THE PRECAST CONCRETE WELL.
 - TAKE CAUTION NOT TO PINCH OR TEAR THE BAG WHEN LOWERING INTO THE WELL.
 - TURN THE STEEL LID WHILE LOWERING TO HAVE THE ACCESS LID FACING THE DESIRED DIRECTION.

NOTE:
ALL DIMENSIONS ARE IN INCHES UNLESS OTHERWISE SPECIFIED

IDENTIFICATION SIGNAGE

STEP No.8



INSTALLATION
INSTRUCTIONS

SS-4



SP-6 IDENTIFICATION SIGNAGE

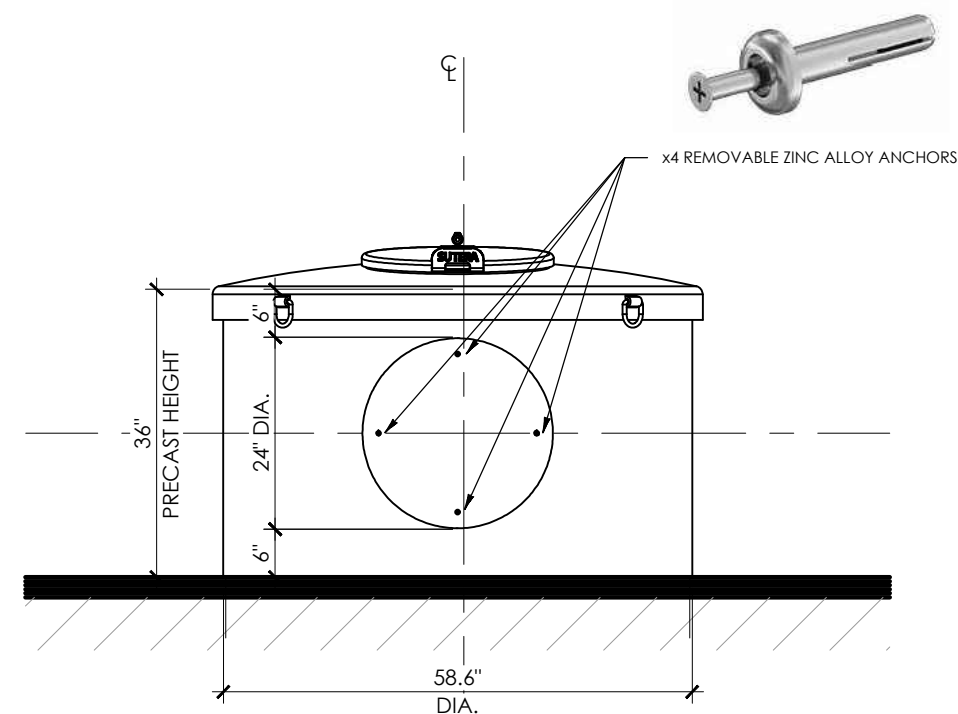

- STEP No.8 - IDENTIFICATION SIGNAGE
- 24" inch DIA. 3M LABEL MOUNTED ON PRE-ROLLED ALUMINUM PLATE.
 - FOUR (x4) REMOVABLE ZINC ALLOY ANCHORS HOLD SIGN IN PLACE.
 - USING THE PRE-DRILLED HOLES ON THE SIGNAGE, MARK AND DRILL FOUR (x4) 0.25" DIA. HOLES IN PRECAST, 1.75" DEEP.
 - HAMMER GENTLY ANCHORS INTO PLACE, TAKING CAUTION NOT TO DAMAGE THE SIGNAGE.

NOTE:
ALL DIMENSIONS ARE
IN INCHES UNLESS
OTHERWISE SPECIFIED



ENSURE THE FOLLOWING IS DONE PRIOR TO COMPLETION:

- ENSURE ALL DEBRIS AND WASTE IS REMOVED CAUSED BY INSTALLATION.
- WIPE CLEAN ENTIRE UNIT WITH CLEAN RAG AND MILD DETERGENT.
- SPRAY ALL EXPOSED STEEL WITH KROWN RUST PROOFING & LUBRICANT. DO NOT WIPE OFF IMMEDIATELY, ALLOW TO PENETRATE FOR 24 HRS.
- SPRAY ALL MOVING COMPONENTS, KEY HOLE AND UNDERSIDE OF PUSH PAD ON SLAM LATCH ASSEMBLY WITH WHITE LITHIUM GREASE.

INSTALLATION IS COMPLETE