



# CS-2

Sutera USA LLC - 55 Commerce Center, Greenville SC. 29615 USA  
 Sutera Canada Inc. - 700 Rupert Street, Waterloo ON. N2V 2B5 CANADA

Description	Designed to safely and securely contain used cooking oil in-ground, where it is kept cool and reduces odors. The containment is fire proof, animal proof and impact resistant, by utilizing concrete and steel construction. Serviced by vacuum truck.
Materials	<p>Steel Lid:</p> <ul style="list-style-type: none"> <li>- Carbon steel c/w 3 part powder coat finish</li> <li>- All fastening hardware is stainless steel</li> </ul> <p>Precast Concrete Containment Well:</p> <ul style="list-style-type: none"> <li>- High strength, steel reinforced concrete with high sulfate resistant cement</li> <li>- Overall mass exceeds the natural forces of hydrostatic pressure (will not float)</li> <li>- All precast risers and bases contain 2 swift lift hook anchors for lifting</li> </ul>
Technical Data	<p>Dimensions:</p> <p>Large Steel Lid = 61.25" dia. (1556 mm), Convex Curve = +3.5" (89 mm)          Steel Access Lid Opening = 23" dia. (584 mm)          Access height above finished grade = 9" (229 mm)          Precast Concrete Inside Dia. = 48" (1219 mm), Outside Dia. = 58" (1473 mm)          Precast Concrete Inside Depth = 36" (914 mm), Overall Height = 42" (1067 mm)</p> <p>Weights:</p> <p>Steel Lid = 385 lbs (175 kg)          Precast Concrete: Monobase = 3975 lbs (1803 kg)</p> <p>Volume:</p> <p>Containment Capacity = 1.40 cu.yds (1068 liters / 282 US Gal.)</p>
Maintenance Instructions	<p>Spray all exposed steel components with Krown Rust Proofing &amp; Lubricant every 12 months. Do not wipe off immediately, allow product to penetrate for 24 hrs.</p> <p>Spray White Lithium Grease to the following locations every three months, more frequently in colder weather.</p> <ul style="list-style-type: none"> <li>- key hole of locking mechanism of slam latch assembly</li> <li>- underside of push pad of the slam latch assembly</li> <li>- all moving components (slam latch, hinges, pivot points)</li> </ul> <p>Note: White Lithium Grease does not freeze in cold temperatures</p> <p>Entire Exterior of unit should be kept clean with soap and water, clean as required.</p>

For more information about this product visit [www.sutera-inground.com](http://www.sutera-inground.com) or email [contact@sutera-inground.com](mailto:contact@sutera-inground.com)

Sutera USA LLC - 55 Commerce Center, Greenville SC. 29615 USA  
Sutera Canada Inc. - 700 Rupert Street, Waterloo ON. N2V 2B5 CANADA

Top View

NOTE: ALL DIMENSIONS SHOWN ARE IN INCHES UNLESS OTHERWISE SPECIFIED

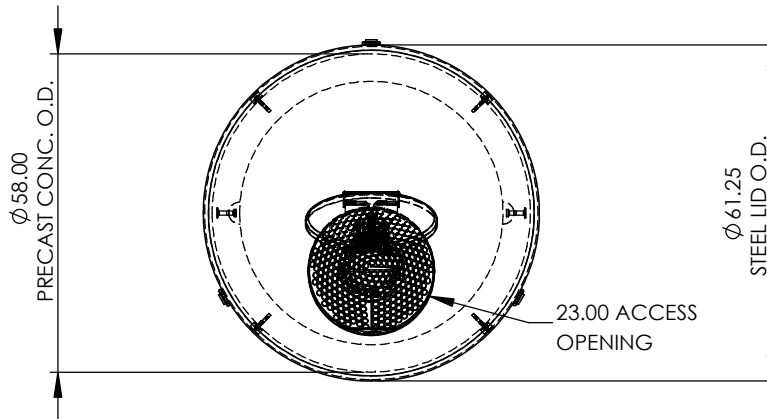

Front View

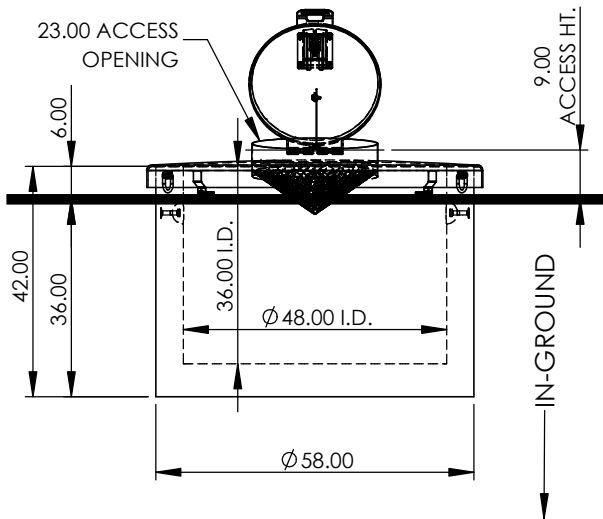

Section View

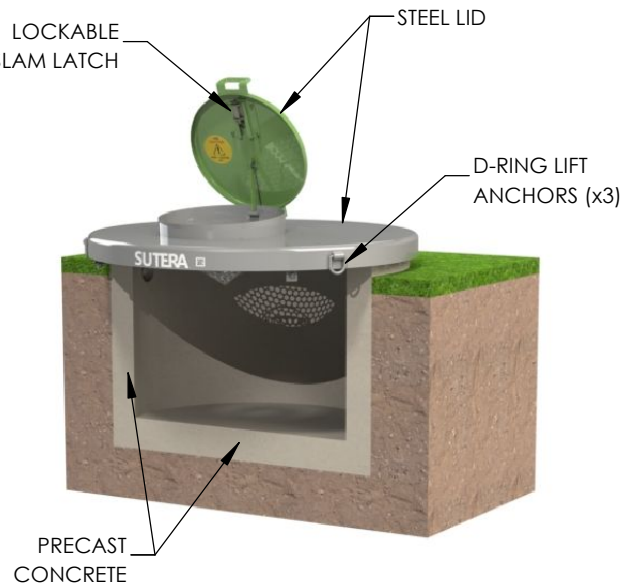

For more information about this product visit [www.sutera-inground.com](http://www.sutera-inground.com) or email [contact@sutera-inground.com](mailto:contact@sutera-inground.com)