



PRS-2

Sutera USA LLC - 55 Commerce Center, Greenville SC. 29615 USA
 Sutera Canada Inc. - 700 Rupert Street, Waterloo ON. N2V 2B5 CANADA

Description	Designed to safely and securely contain waste in-ground, where it is kept cool and reduces odors. The containment is fire proof, animal proof and impact resistant, by utilizing concrete and steel construction. Service by vertical lift crane truck.
Materials	<p>Steel Lid:</p> <ul style="list-style-type: none"> - Carbon steel c/w 3 part powder coat finish - All fastening hardware is stainless steel <p>Precast Concrete Containment Well:</p> <ul style="list-style-type: none"> - High strength, steel reinforced concrete with high sulfate resistant cement - Overall mass exceeds the natural forces of hydrostatic pressure (will not float) - All precast risers and bases contain 2 swift lift hook anchors for lifting <p>Reusable Containment Bag</p> <ul style="list-style-type: none"> - 18 oz. PVC coated polyester bag - Heavy duty bag hardware for cinching the bag closed
Technical Data	<p>Dimensions:</p> <p>Large Steel Lid = 48.25" dia. (1226 mm), Convex Curve = +1.0" (25 mm) Steel Access Lid Opening = 10" dia. (254 mm) Access height above finished grade = 36" (915 mm) Precast Concrete Inside Dia. = 36" (914 mm), Outside Dia. = 45.5" (1156 mm) Precast Concrete Inside Depth = 86.3" (2192 mm), Overall Height = 98.3" (2497 mm)</p> <p>Weights:</p> <p>Steel Lid = 370 lbs (168 kg) Precast Concrete: Plug = 1757 lbs (797 kg), Riser = 4797 lbs (2176 kg)</p> <p>Volume:</p> <p>Containment Capacity = 1.88 cu.yds (1438 liters)</p>
Maintenance Instructions	<p>Spray all exposed steel components with Krown Rust Proofing & Lubricant every 12 months. Do not wipe off immediately, allow product to penetrate for 24 hrs.</p> <p>Spray White Lithium Grease to the following locations every three months, more frequently in colder weather.</p> <ul style="list-style-type: none"> - key hole of locking mechanism of slam latch assembly - underside of push pad of the slam latch assembly - all moving components (slam latch, hinges, pivot points) <p>Note: White Lithium Grease does not freeze in cold temperatures</p> <p>Entire Exterior of unit should be kept clean with soap and water, clean as required.</p>

For more information about this product visit www.sutera-inground.com or email contact@sutera-inground.com

PRS-2

Sutera USA LLC - 55 Commerce Center, Greenville SC. 29615 USA
Sutera Canada Inc. - 700 Rupert Street, Waterloo ON. N2V 2B5 CANADA

Top View

NOTE: ALL DIMENSIONS SHOWN ARE IN INCHES UNLESS OTHERWISE SPECIFIED

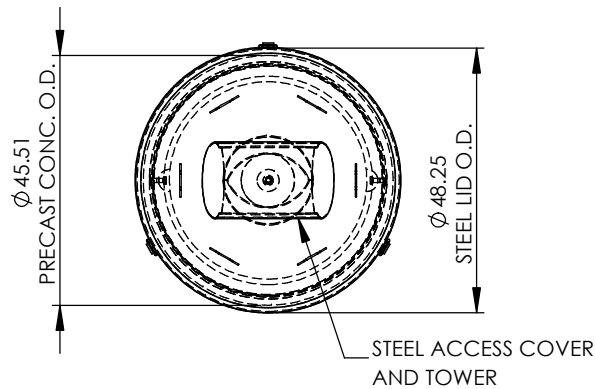

Front View

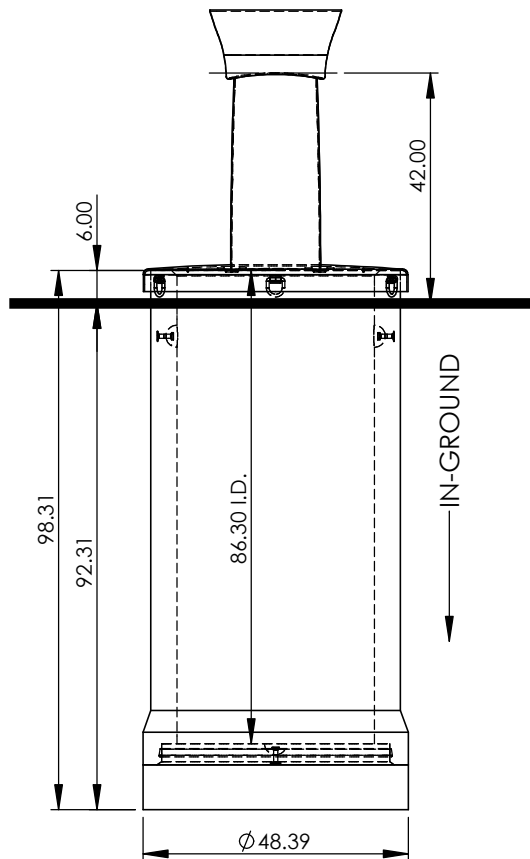

Section View

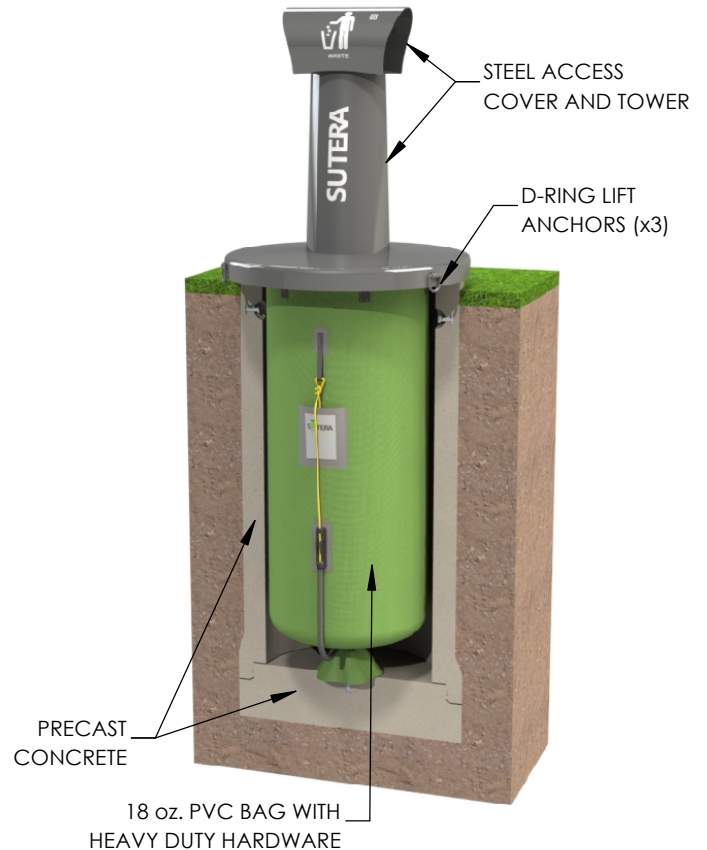

For more information about this product visit www.sutera-inground.com or email contact@sutera-inground.com